

THIS DRAWING IS UNPUBLISHED. RELEASED FOR PUBLICATION
 © COPYRIGHT BY TYCO ELECTRONICS CORPORATION. ALL INTERNATIONAL RIGHTS RESERVED.

LOC	DIST	REVISIONS				
P	LTR	DESCRIPTION	DATE	DWN	APVD	
AF	50	Z1	REVISED PER ECR-08-017318	14JUL08	HMR PD	

- 1 CONTINUOUS STRIP ON REELS.
- 2 PRELIMINARY - NOT FOR PRODUCTION.
- 3 PART TO BE PUT ON PLASTIC REELS

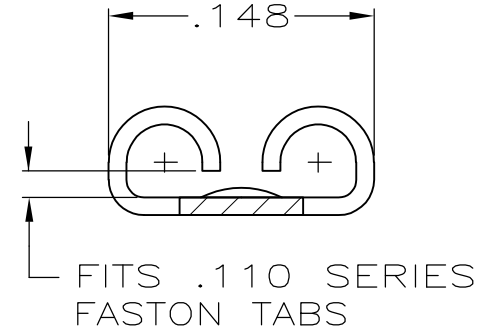
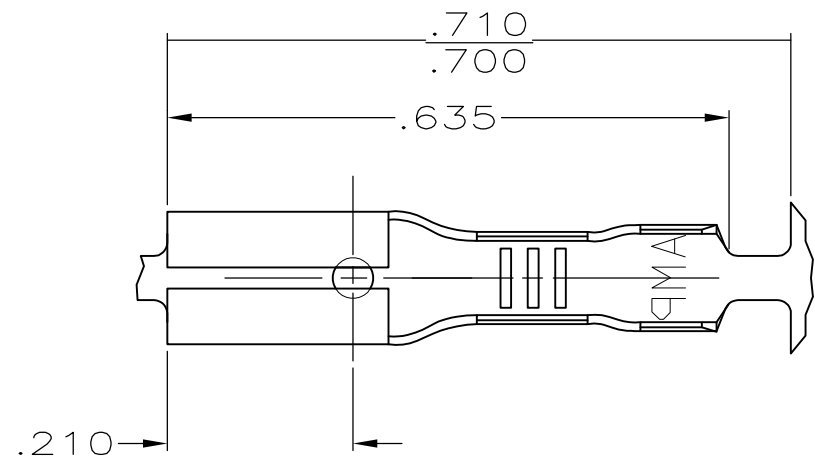

VIEW A-A
SCALE 10:1

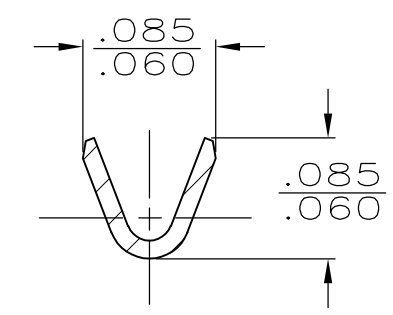
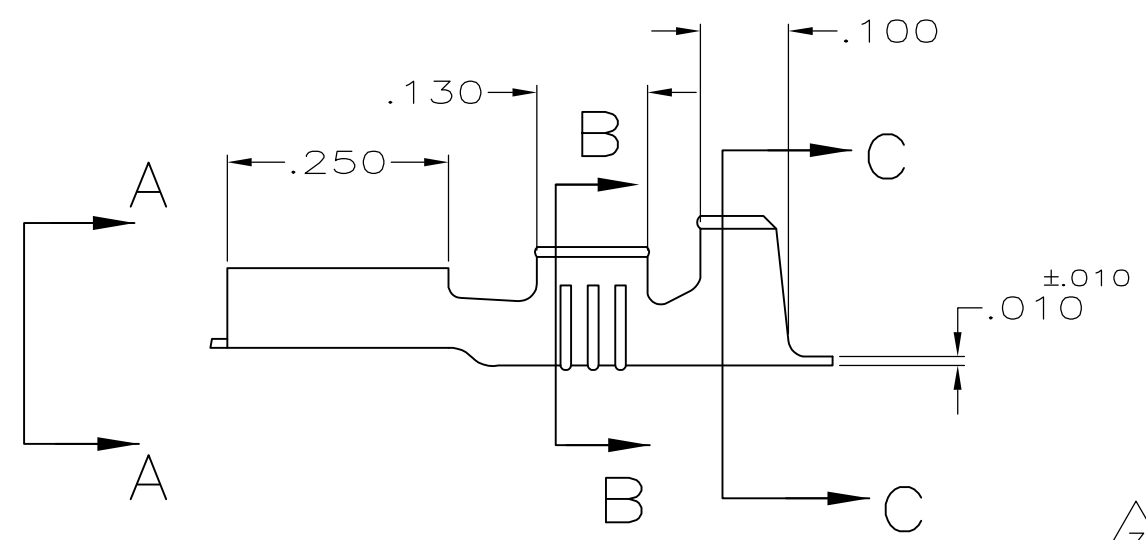

SECTION B-B
SCALE 10:1

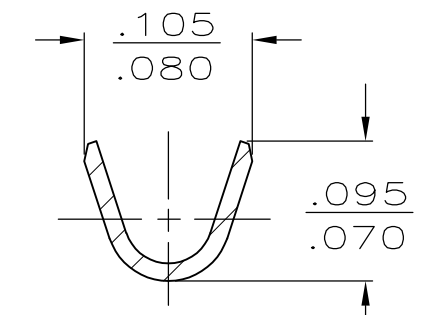

SECTION C-C
SCALE 10:1

3	2	PRE-TIN	.040-.060	#24-#22	.016	42415-5
		PRE-TIN	.040-.060	#24-#22	.016	42415-1
		FINISH	INSUL RANGE	WIRE SIZE	MATING TAB THK ±.001	PART NO.

THIS DRAWING IS A CONTROLLED DOCUMENT.		DWN JR RUTH 3/27/91	Tyco Electronics Corporation Harrisburg, PA 17105-3608			
DIMENSIONS: mm [INCHES]		CHK MS FEHER 3/27/91				
TOLERANCES UNLESS OTHERWISE SPECIFIED:		APVD C MEYERS 3/27/91	RECEPTACLE, FASTON, .110 SERIES			
0 PLC ± -		PRODUCT SPEC 3/27/91 D REINER				
1 PLC ± -		APPLICATION SPEC	SIZE	CAGE CODE	DRAWING NO	RESTRICTED TO
2 PLC ± -			A3	00779	C-42415	-
3 PLC ± .015			CUSTOMER DRAWING			
4 PLC ± -			SCALE	SHEET	REV	
ANGLES ± -			5:1	1 OF 1	Z1	
MATERIAL #4H BRASS	FINISH SEE TABLE	WEIGHT -				